

FIXTURE LAYOUT DESIGN BASED ON A SINGLE-SURFACE CLAMPING WITH LOCAL DEFORMATION

Tadic, B. ^{*}; Todorovic, P. ^{*}; Novkinic, B. ^{**}; Buchmeister, B. ^{***}; Radenkovic, M. ^{*}; Budak, I. ^{****}
& Vukelic, D. ^{****}

^{*} University of Kragujevac, Faculty of Engineering, Sestre Janjic 6, Kragujevac, Serbia

^{**} Ministry of Defence, Kraljice Marije bb, Banja Luka, Bosnia and Herzegovina

^{***} University of Maribor, Faculty of Mechanical Engineering, Smetanova 17, Maribor, Slovenia

^{****} University of Novi Sad, Faculty of Technical Sciences, Trg Dositeja Obradovica 6, Novi Sad, Serbia

E-Mail: btadic@kg.ac.rs, petar@kg.ac.rs, bekir_novkinic@hotmail.com, borut.buchmeister@um.si,
radenkovic@kg.ac.rs, budaki@uns.ac.rs, vukelic@uns.ac.rs

Abstract

Proposed in this paper is a novel approach to fixture layout design. The contact interface between workpiece and fixture is reduced to a single workpiece surface. This allows reliable machining of the remaining five workpiece surfaces in a single setup. Workpiece clamping is performed by inserting special elements into prepared auxiliary openings on the workpiece. Clamping is thus reduced to indenting of sharp clamping element tips into the workpiece surface. Shallow indenting is performed on surfaces which have no practical function. Special device was designed to allow experimental investigation. Experimental results point towards the efficiency of the proposed approach. Workpiece displacements were small during machining and allowed the required machining accuracy. Furthermore, the results obtained during machining indicate high surface quality.

(Received in August 2014, accepted in January 2015. This paper was with the authors 1 month for 1 revision.)

Key Words: Fixture, Machining, Locating, Clamping

1. INTRODUCTION

Companies are always trying to stay competitive on the world market and to improve their work and products by making them better, cheaper, safer and adding value. One of the most important manufacturing problems is how to create quality products within short timeframes. Short release time of new products is one way to stay ahead of competitors and to ensure bigger profit. Next to this, costumers are used to variety so that's one more problem for manufacturers since they need to create new manufacturing practices to ensure faster turnaround in product development. Flexible manufacturing can not be achieved without using flexible fixtures, so one fixturing element can be used on several manufacturing operations [1]. Costs regarding fixturing are not very small and they influence from 10 % to 20 % of total costs of manufacturing system [2]. Around 40 % of all rejected parts are due to dimensioning errors that has appeared because of poor fixturing design [3].

Fixture layout plays an important role at the machining process planning stage. Optimization of fixture layout is a critical aspect of machining fixture design, defining the types, number, and material of fixture elements, and their position relative to workpiece [4]. Most frequently, goal function was minimization elastic workpiece deformation, minimization deformation at workpiece-fixture contact points, minimization clamping forces, minimization workpiece location errors (improve the location accuracy), minimization vibration during machining, etc. Numerous approaches have been used to determine optimal fixture layout.

Siebenaler and Melkote [5] presented a fixture-workpiece model using finite element method (FEM) to investigate the influence of various parameters on workpiece deformation,

including the compliance of the fixture body, contact friction, and mesh density. Prabhakaran et al. [6] presented a fixture layout optimization method that used genetic algorithm (GA) and ant colony algorithm (ACA) separately. The workpiece deformation was modelled using FEM for the problems of fixture layout optimization with the objective of minimizing the dimensional and form errors. Liu et al. [7] proposed a method to optimize the fixture layout in the peripheral milling of a low-rigidity workpiece. This paper dealt with the optimization of the number and positions of the locators only on the secondary locating surface. Padmanaban et al. [8] used an ACA-based discrete optimization method to optimize fixture layout under dynamic conditions. They also proved that in the fixture layout optimization ACA outperformed GA. Padmanaban et al. [9] optimized fixture layout for 2-D workpiece geometry with an objective of minimizing the workpiece elastic deformation using ACA-based discrete and continuous fixture layout optimization methods. Hunter et al. [10] proposed an automatic fixture design using a development model. A knowledge-based engineering application was developed using knowledge model for the fixture design. Zheng and Chew [11] used the Gilbert-Johnson-Keerthi distance algorithm and the Gram-Schmidt process to yield candidate points and an interchange algorithm for altering the points to meet form-closure and to increase an immobilization capability index of fixture layouts. Hazarika et al. [12] developed setup planning methodology for prismatic parts generating optimal layout of locating and clamping elements, and providing their sizes. The objective was to minimize the maximum of locating elements reaction forces during machining. Layout was optimized as constrained optimization problem and solved using nonlinear optimization. Asante [13] investigated the effect of fixture compliance and cutting conditions on workpiece stability. He used the minimum eigenvalue of the fixture stiffness matrix (which represents minimum displacements at the contact points) locating and clamping elements, as well as the largest displacement of the workpiece due to the cutting forces to assess the stability of the workpiece. Lu et al. [14] discussed the stability of workpiece-fixture system and quantitative optimization of clamping forces during cutting process. Based on the force screw theory and the minimum norm principle, a mathematical model is formulated to calculate the entire passive forces acting on the workpiece. Chaari et al. [15] presented a modelling methodology for geometrical machining defect. The kinematical deviation due to part locating and relocating is modelled by homogeneous transformation. Dynamic displacements caused by clamping and machining force are determined by FEA. Vishnupriyan et al. [16] presented a method for determination of optimal fixture layout in order to minimize the machining error considering both locator geometric error and workpiece elastic deformation. Vishnupriyan [17] investigated the significance of system compliance and workpiece dynamics as the two critical sources of machining error. Considering different layouts and various clamping forces, the resulting components of machining error were computed. Sun et al. [18] developed an integrated setup/fixture planning approach to identify the optimal and practical setup/fixture plan. The setup/fixture planning methods can be classified into three categories: multi-constraints, fixture driven, and tolerance analysis planning methods. Vishnupriyan et al. [19] proposed a method of using an artificial neural network (ANN) for the prediction of workpiece dynamic motion. Different layouts are obtained using a modular fixture and actual machining is performed on the workpiece. Siva Kumar and Paulraj [20] developed a methodology that analyses and optimizes the fixture parameter configurations using a GA with an ANSYS parametric design language of a finite element analysis that minimizes the geometric dimensional tolerance errors of the final component dimensions during drilling operation. Tadic et al. [21] proposed an approach to workpiece clamping based on intentional plastic deformation of workpiece. In order to increase load capacity and reduce compliance, a method was proposed based on indenting sharp cone-shaped clamping elements into workpiece material using rough surfaces with no specific demands regarding finish. Dou et al.

[22] investigated a methodology for optimal placement of locating/clamping elements under dynamic conditions using evolutionary techniques. Dynamic response of workpiece under time-varying machining force is taken into account when optimizing the fixture layout in order to minimize the maximum elastic deformation of the workpiece in machining region. Vukelic et al. [23] investigated workpiece-fixture interface compliance in cases where clamping is performed using a standard, and specially designed clamping element. The investigation showed that the specially designed clamping element can increase workpiece/fixture load capacity and diminish interface compliance. Tadic et al. [24] proposed a general model for locating and clamping thin-wall workpieces of complex geometry with two skewed holes under multiple constraints. Numerous constraints related to application of the proposed model are discussed as prerequisite to design of fixture solution. Wan et al. [25] proposed a new analytical technique to determine the effect of fixture layout on the dynamic response of thin-wall multi-framed workpiece during machining. Double functions of Euler-Bernoulli beam can be utilized to describe mode shape of a thin-wall multi-framed workpiece. Liu et al. [26] developed a geometrics model considering both the workpiece surface and the locator shape to measure the locating performance, an accelerated FEM model is developed to compute the node displacements under external forces, and a multi-objective optimal method is constructed to obtain an optimal fixture layout and clamping force. Xiong et al. [27] proposed N-2-1-1 supporting strategy for the support of thin and large workpieces. The strategy has been developed specifically for use with the SwarmItFix fixture concept. Based on such strategy, a global optimal algorithm integrating FEM and a GA are proposed. Tadic et al. [28] proposed an approach to workpiece clamping based on plastic deformation of workpiece in predefined narrow zones, and analyzed load capacity and interface compliance. The results of experimental investigation showed that, under certain conditions, the clamping/locating elements with larger-radius spherical tips provided significantly lower interface compliance. Todorovic et al. [29] proposed a model that allows simulation of the behaviour of all kinds of interfaces between fixture elements and workpiece, under arbitrary dynamic loads. Workpiece displacement relative to fixture element was determined by analytical solution of the Lagrange differential equations of motion. Interface stiffness and damping coefficient were determined experimentally to machining of thin-walled workpieces. Nelaturi et al. [30] demonstrated a novel algorithm to rapidly compute a set of clamping locations, using the principles of force and form closure, that ensure for a specified polyhedral workpiece stability under the application of external forces.

Analysis of previous investigations yields several conclusions. Wrong or inadequate fixturing process can lead to workpiece deformations, as well as the workpiece displacement, which can significantly affect final workpiece accuracy. On the other hand, insufficient clamping force can cause the workpiece to move during machining and detach from fixture elements, which renders the fixturing process ineffective. Accuracy, deformations and distortions of workpiece can be minimized by optimizing locating scheme (the number, type and disposition of locating elements) and clamping scheme (the number, type and disposition of clamping elements, and clamping force magnitude). Fixture layout is gaining importance bearing in mind that modern manufacturing often demands fixtures which need to provide locating and clamping for workpieces which are to be machined within a single set-up, using a number of cutting tools with a multitude of cutting regimes and chip cross-sections which vary along the tool path. The traditional 3-2-1 approach to workpiece locating allows machining to be performed in a limited number of cutting planes since some fixture elements obstruct machining in other planes due to possible collisions between cutting tools and fixture elements. One of important factors of increased cutting productivity and accuracy is to allow machining of as many surfaces as possible with a single locating and clamping.

This paper presents a new clamping method which uses only one surface for fixturing. This disfunctional surface must be used as the datum surface and it is necessary to have two technological holes, which will later be used to establish contact between workpiece and clamping element. The proposed new fixture can be used in several steps of manufacturing process. This fixture provides stability for small workpieces, with locating and clamping over the bottom side which is necessary for machining in five planes. Presented in this paper is a novel fixture design accompanied by FEM analysis which was used to discuss possible problems. Experimental investigations were performed with a fixture which uses clamping elements which make indents on the surface of specially designed technological holes. During machining process, workpiece displacements were monitored to analyze reliability of the proposed clamping method and the resulting machining error. Surface roughness was also measured within the characteristic workpiece areas.

2. THEORETICAL CONSIDERATIONS

A workpiece with complex geometry is considered which requires machining in five planes with a single set-up. In Fig. 1 a general case of the problem is shown. A possibility is considered to locate and clamp such type of workpiece, over the only remaining sixth surface. The idea is to machine to small auxiliary openings on the sixth plane to allow introduction of clamping elements.

The clamping should provide unambiguous location of workpiece relative to coordinate system x, y, z , using clamping elements which are anchored within two relatively small auxiliary openings. In this case, the clamping forces should provide reliable contact between workpiece and locating surface, as well as the sufficient magnitude of the reaction forces which balance the cutting forces and moments, regardless of their direction and sense. The cutting force, F_c , and the cutting moment, M_c , which act upon workpiece, tend to dislocate it from the required position, as shown in Fig. 1. Generally, the cutting force and cutting moment have components which are projected in the directions of x, y and z axes. In order for the clamping method to be reliable, it is necessary to provide with the clamping elements reaction forces which are sufficient to balance the cutting force, F_c , and cutting moment, M_c . Moreover, to prevent workpiece displacement, the magnitudes of reaction forces and moments (R_A, R_B, M_A and M_B) which act upon the surfaces of auxiliary openings, A and B (Fig. 1), should never drop below the magnitude of the resulting cutting forces and moments.

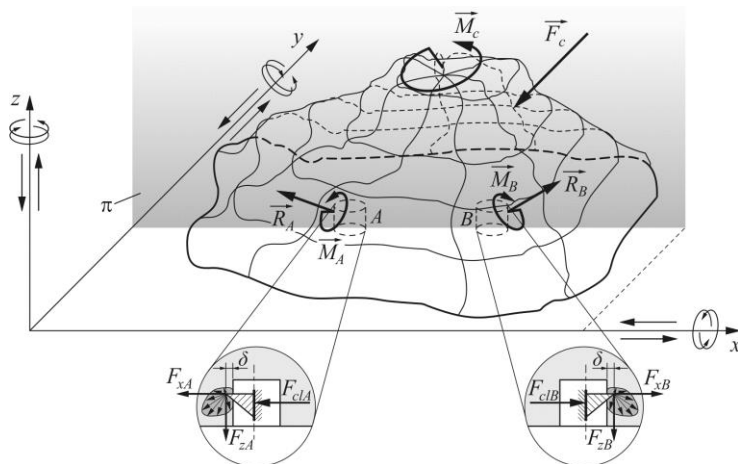

Figure 1: Schematic drawing of the proposed clamping of complex-geometry workpiece.

From the theoretical point of view, the clamping element is designed as a conical wedge which is indented locally and deforms a small volume of the auxiliary opening surface.

The details showing neighbourhoods of points A and B (Fig. 1), reveal the contact interface between clamping element and workpiece, i.e. the global stress distribution field and reaction force on clamping element projected onto plane π , which is parallel to yz plane. The reaction forces are provided by the rectilinear movement of the conical edge along the x axis, which acts upon the clamping elements with clamping forces F_{clA} and F_{clB} . Due to these clamping forces, the clamping element moves along x axis and creates a lateral indent into the wall of the auxiliary hole on the workpiece, up to depth δ (Fig. 1, details of A and B point neighbourhoods). In order for this clamping method to be possible, the material of clamping element must be of a much higher hardness than the workpiece material. Clamping forces F_{clA} and F_{clB} act upon the clamping elements A and B and provide the necessary reaction forces (R_A, R_B, M_A and M_B). The intent is to adjust the geometry of clamping wedge so as to indent it into the inner surface of auxiliary hole under the influence of the force acting in the z axis direction. This force is essential to providing firm contact between workpiece and locating surface. Forces F_{xA} and F_{xB} which are of equal magnitudes, but different senses, keep most of the dynamic forces and moments during the cutting in equilibrium.

The magnitudes of reaction forces and moments for each clamping element define the equilibrium conditions given as vector equations:

$$\vec{R}_A + \vec{R}_B = \vec{F}_c \quad (1)$$

$$\vec{M}_A + \vec{M}_B = \vec{M}_c \quad (2)$$

The proposed methodology assumes that the clamping method is able to provide the required magnitudes of reaction forces at relatively small depths of indent made by the conical wedges into the surface of previously made auxiliary openings. With this in mind, numerical simulations were conducted in order to establish the magnitudes of reaction forces (R_A and R_B) and the corresponding depths of indent.

3. NUMERICAL SIMULATIONS

In order to verify the theoretical model, FEM analysis was conducted. Using SimuFact Forming V9 software, a case was analyzed in which a complex-geometry workpiece was clamped by indenting a conical wedge element (CW) by the depth of $\delta = 0.20$ mm (Fig. 2), where the cone angle was 60° , and maximum diameter of the conical wedge was 6 mm.

Fig. 3 presents the schematic drawing of the fixture for which the FEM analysis was conducted. Using conical wedge CW, external force F_{cw} is transformed into clamping forces, F_{clA} and F_{clB} , at the points of contact with the clamping elements, CP. It results in the clamping elements, CP, being indented into the workpiece, WP, up to the depth of δ . The detail shown in Fig. 2 represents the cross-section P-P in the neighbourhood of point A from Fig. 3.

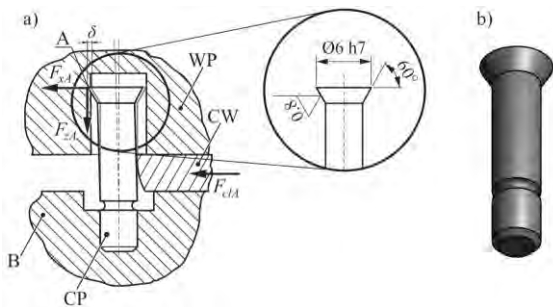

Figure 2: Clamping element geometry; a) detail of A point neighbourhood, b) 3D view of conical wedge element.

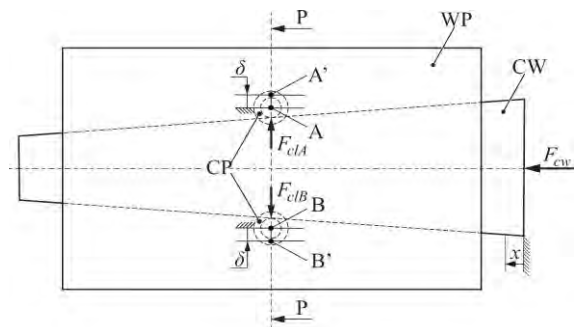

Figure 3: Workpiece clamping scheme.

Considering the large difference between the hardness of workpiece and clamping element, for the purpose of simulation, the clamping element is considered as absolutely rigid body, while the workpiece is made of material EN AW-6082 (AlMgSi1). Contact interface was modelled using friction coefficient $\mu = 0.15$. Finite elements mesh consisted of 13602 Overlay Hex hexahedral elements, the size of 2 mm. Within the contact interface area the mesh was significantly refined (Fig. 4).

Numerical simulations were conducted in order to determine the magnitudes of reaction forces acting on the clamping elements in the direction of x and z axes as the result of indenting the clamping into surfaces of auxiliary openings. Stress distribution in the contact interface zone was also obtained by simulation. Shown in Fig. 5 is the stress distribution within the workpiece/fixture contact interface zone, for $\delta = 0.20$ mm indenting depth. Geometries of auxiliary opening and indenter are shown in Fig. 2. It is notable that stress magnitude within the contact interface reaches 378 MPa.

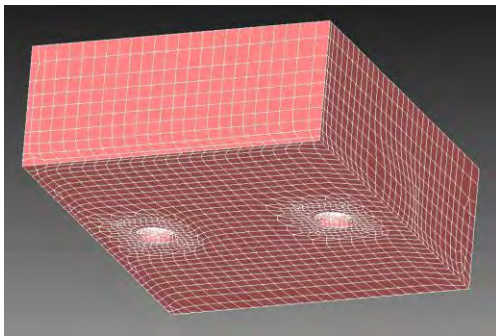

Figure 4: Meshed workpiece.

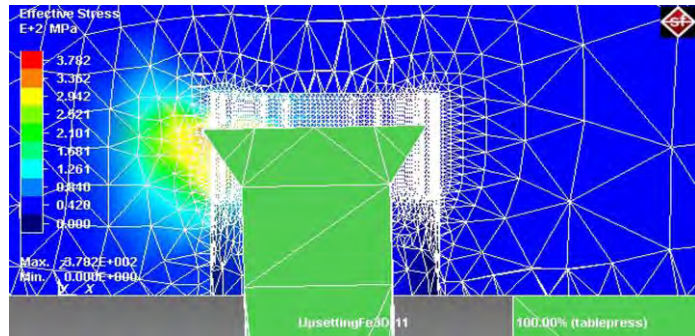

Figure 5: Stress distribution within the workpiece/fixture interface zone.

Magnitudes of reaction forces in the direction of x and z axes are given in Fig. 6. It should be noted that the initial clearance between the clamping elements and workpiece is 0.08 mm, at which moment the reaction forces equal zero (Fig. 6). After that, the contact between the clamping element and workpiece is initiated, causing elasto-plastic deformations in the contact interface zone, followed by a constant increase in reaction force. Maximum value of reaction force which acts upon the clamping element appears along z axis and equals 1077.21 N. This confirms the assumption that there is a reaction force along z axis which pre-loads the workpiece, thus preventing lift-off effect.

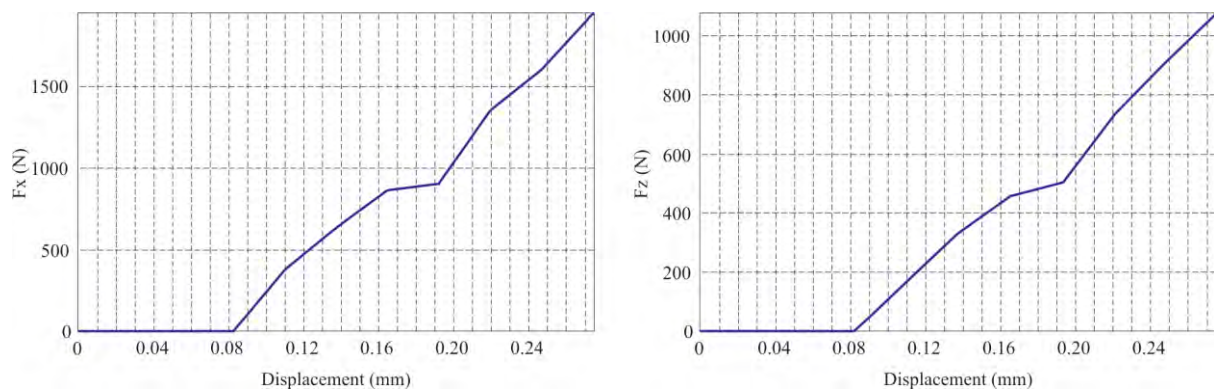

Figure 6: Reaction forces on the clamping element at A point neighbourhood obtained by FEM simulation.

Based on the presented calculations it can be assumed that the reaction forces on the clamping elements are sufficient to assure the unambiguous workpiece position, under the recommended cutting regimes, while the workpiece displacements remain within limits which

enable required machining accuracy. The magnitudes of stresses which occur within the contact interface zone are beyond the 250 MPa yield boundary of workpiece material. Thus, both elastic and plastic deformations are present in the contact interface zone.

4. EXPERIMENTAL INVESTIGATION

Experimental investigations were conducted to identify workpiece displacements and surface quality during machining process in five planes, using loads which correspond to recommended cutting regimes. This would allow realistic assessment of the proposed locating and clamping method. Workpiece material was aluminum alloy, EN AW-6082 (AlMgSi1). Its chemical and mechanical properties are given in Table I and Table II, respectively.

Table I: Chemical composition of workpiece material EN AW-6082 (AlMgSi1).

Elements	Si	Fe	Mn	Mg	Cr	Zn	Ti	Al
wt. (%)	0.9	0.5	0.6	0.9	0.25	0.2	0.1	Balance

Table II: Mechanical properties of workpiece material EN AW-6082 (AlMgSi1).

Tensile strength R_m (N/mm ²)	Yield strength $R_{p0.2}$ (N/mm ²)	Brinell hardness HB	Specific gravity G (g/cm ³)	Elastic module E (GPa)	Lin. coeff. of therm. exp. (20-100°C) α ($\mu\text{m}/\text{m}^\circ\text{C}$)	Thermal conductivity κ (W/mK)
275–300	240–255	89	2.7	69	23.4	165–185

The workpiece had following dimensions: 50×60×30 mm. Its geometry, prior to and after machining, is shown in Fig. 7. Auxiliary openings which were used for clamping are located on the bottom workpiece surface, as shown in Fig. 3, where the clamping method is illustrated, and can also be seen in Fig. 4, where the FEM model is shown. The fixture, used in experiment, is shown in Fig. 8, both as the 3-D model and in a photo-image. As mentioned before, the axial movement of the conical wedge, CW, results in the displacement of the clamping element, CP, and its indenting into workpiece, WP, which provides the necessary clamping forces required to keep the cutting forces in equilibrium.

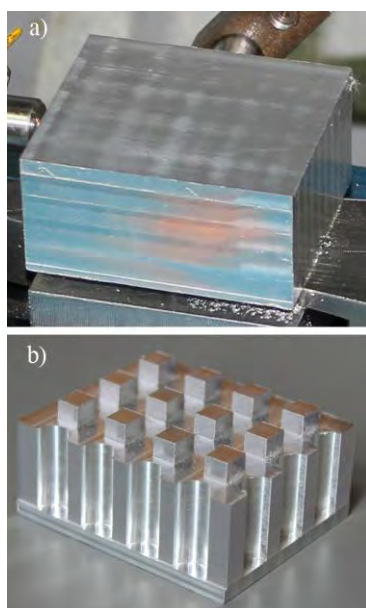

Figure 7: Workpiece; a) before machining, b) after machining.

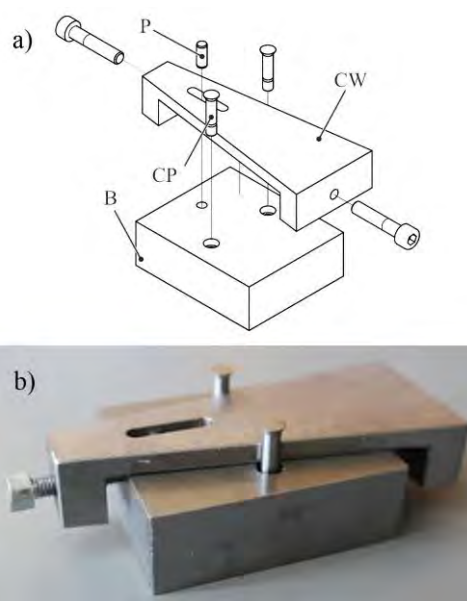

Figure 8: Fixture used to locate and clamp over one plane; a) 3-D model, b) photo-image.

Experimental investigation included measurement of workpiece displacements, in real conditions, during the cutting process. Machining was performed on HAAS TM1 CNC milling machine, with end milling cutter with 8 mm diameter at $n = 3800$ rpm and feed $f = 300$ mm/min. The displacements were measured in two directions, along x and y axes, as shown by the position of two displacement sensors in Fig. 9.

Fig. 9 shows the auxiliary measurement instrumentation, which consists of:

- The inductive displacement transducer WIT (shown as SX and SY in Fig. 9), with nominal displacement of ± 1 mm;
- The 2 channel HBM signal conditioner (shown as SC in Fig. 9) which processes the signals from sensors SY and SX;
- The 8 analog input channels simultaneous sampling data acquisition module with a 16-bit resolution (shown as DAQ in Fig. 3), which was used for sampling of the signal from the SY and the SX; and,
- The PC which controls DAQ module and stores the results of measurement for further processing.

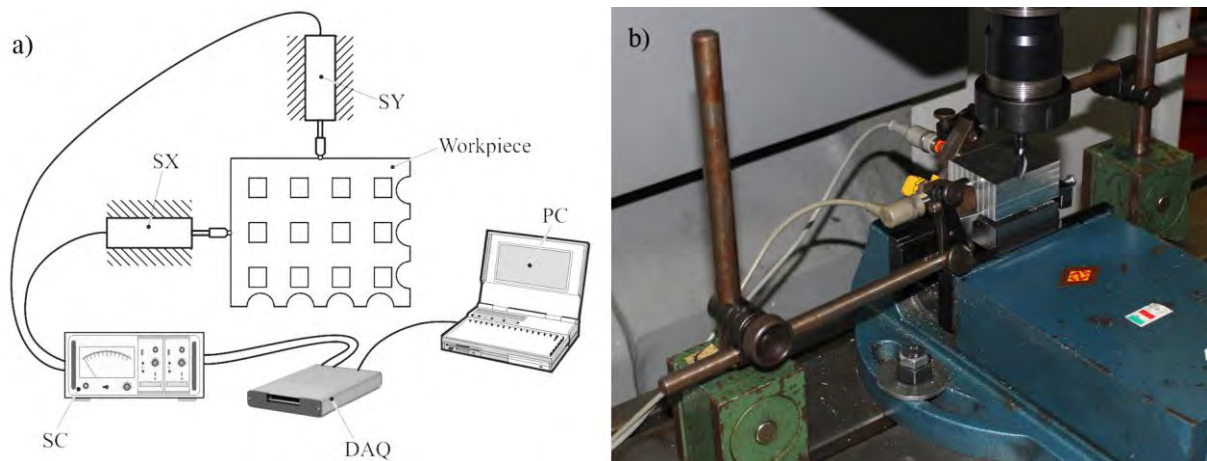

Figure 9: System for the measurement of displacement of fixture-workpiece interface and a photo-image of the measurement system.

It should be noted that the fixture is primarily dedicated to accommodate complex-geometry workpieces, i.e., workpieces which require machining in five planes. However, due to the need to mount the displacement sensor, there are two planes which remained without machining during experiment, which in principle has no bearing on the results and corresponding conclusions. The machining was performed in two machining processes while the cutting tool trajectories are shown in Fig. 10. Shown in Fig. 11 are the displacement measurement results in x and y directions during the first machining process, while Fig. 12 shows a segment of measured displacements in the x and y directions. Based on the diagrams, it can be concluded that the displacements are very small. Histogram (Fig. 11) shows that the displacements are concentrated in the $\pm 1 \mu\text{m}$ region, while maximum displacements remain below $\pm 5 \mu\text{m}$, i.e., below 0.01 mm. In Fig. 12, numerals 1 to 8 are used to designate displacements which correspond to tool positions 1 to 8, shown in Fig. 10a. Largest displacement is recorded at point 5, when the tool changes direction.

Surface roughness was also measured. Surface roughness profiles were measured using a Talysurf 6 profiler with a variable-inductance transducer and a $2 \mu\text{m}$ stylus tip. The selected evaluation length $L = 1.25$ mm contained 1150 sampling points. Shown in Fig. 13 are measurement spots, while Table III presents the values obtained for roughness parameters after workpiece machining. It can be concluded that surface quality is very high (R_a is within

0.063-0.31 μm). This indirectly confirms that the proposed clamping and locating system provides required stability.

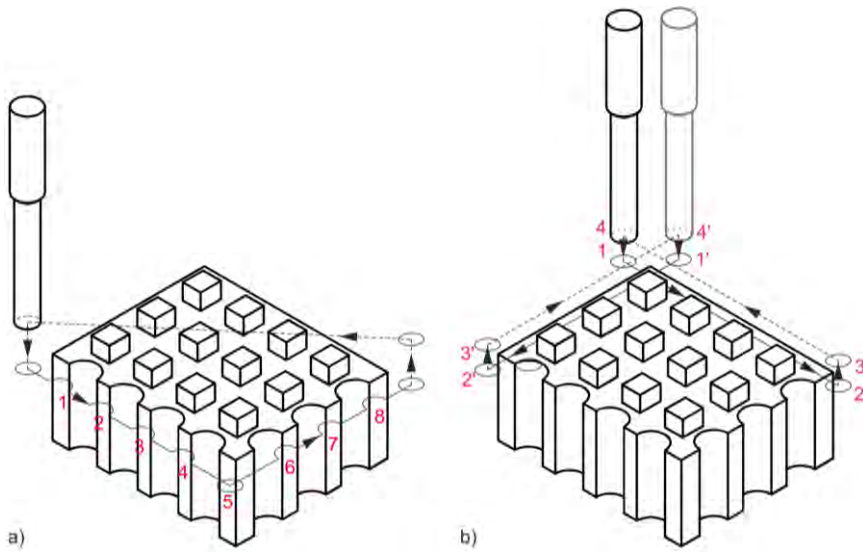

Figure 10: Tool paths used during displacement measurements; a) first machining process, b) second machining process.

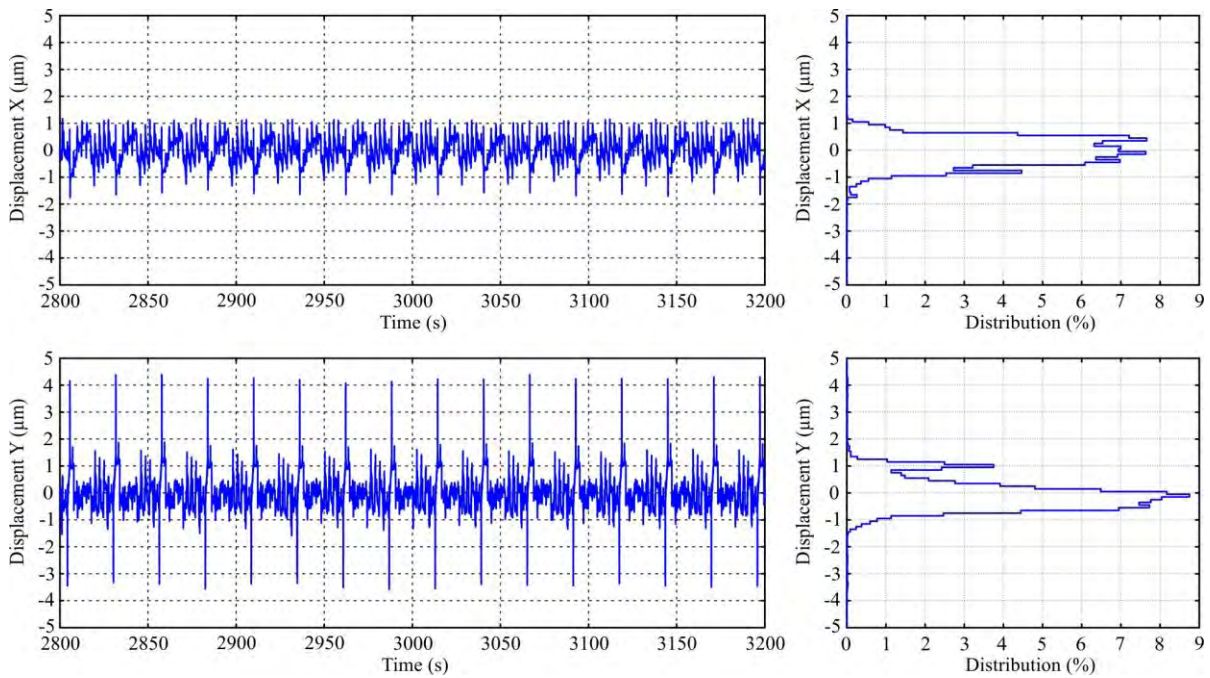

Figure 11: Measured displacements and histograms in x and y direction.

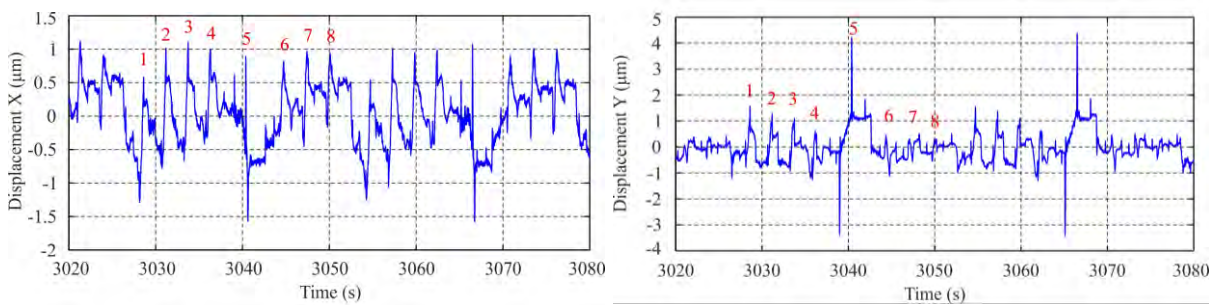

Figure 12: A segment of measured displacements.

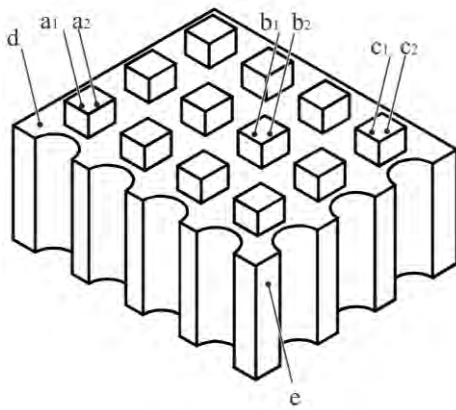

Figure 13: Measurement spots.

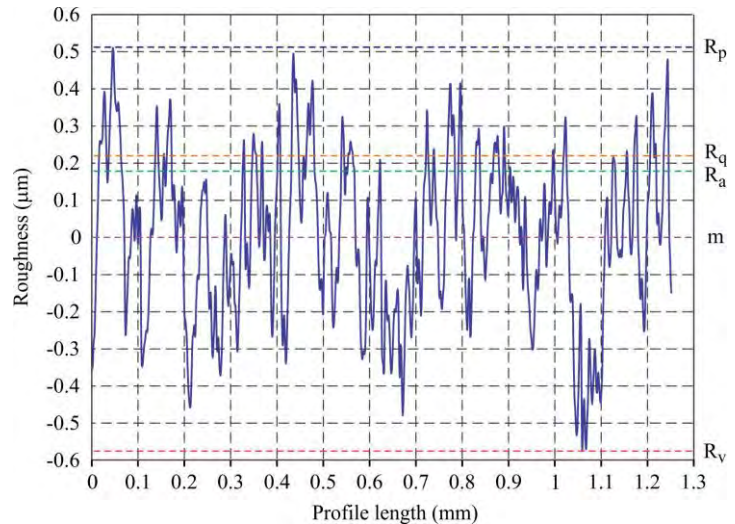

Figure 14: Diagram of measured roughness profile.

Diagram in Fig. 14 presents roughness profile of machined surface. Based on the roughness profile of the machined surface shown in Fig. 14, and the results presented in Table III, it can be concluded that surface quality is very high and equals that of fine grinding.

Table III: Roughness parameters of the finished part.

Measured spot	R_a (μm)	R_p (μm)	R_v (μm)	R_q (μm)
a ₁	0.179	0.51	0.57	0.217
a ₂	0.103	0.33	0.35	0.130
b ₁	0.142	0.53	0.43	0.180
b ₂	0.063	0.18	0.19	0.075
c ₁	0.166	0.60	0.50	0.203
c ₂	0.118	0.43	0.38	0.149
d	0.22	1.2	1.1	0.32
e	0.31	1.1	0.8	0.38

5. DISCUSSION

Based on the conducted FEM simulations, locating and clamping can be successfully performed over a single plane, by indenting conical-wedge clamping elements to a relatively small depth, into the previously auxiliary openings on the workpiece. The results of FEM simulation indicate that even small depths of indent result in high reaction forces, the magnitude of 1000 N. Such reaction forces are able to balance the cutting forces and moments during machining. Thus, it was realistic to suppose that the proposed clamping method can successfully cope with the dynamic loads, i.e., to maintain the workpiece displacements within the tolerance-required boundaries during machining with recommended cutting regimes. Experimental trials conducted in this study confirmed this. The results show the occurrence of very small workpiece displacements, on the 0.01 mm order of magnitude, which satisfies the requirements of machining accuracy. The results of surface roughness measurements also indicate low surface roughness which confirms that the proposed locating and clamping system is stable. Considering all previous statements, the proposed locating and clamping system over a single plane can be successfully used in machining of complex-geometry workpieces which require machining in five planes.

6. CONCLUSION

Locating and clamping of complex-geometry workpieces which require machining in five planes represents a serious problem. Investigations presented and discussed in this paper pertain to theoretical and experimental analysis of a novel method of workpiece locating and clamping over a single plane. Both theory and industrial practice have confirmed the benefits of machining complex-geometry workpieces in several planes using a single plane for locating and clamping.

The analyses conducted allow following conclusions to be drawn:

- Locating and clamping of workpieces which require machining in five planes, while the sixth plane is used for locating and clamping, can be efficiently performed by indenting the clamping elements (conical wedges) into surfaces of auxiliary openings in the workpiece.
- Results of FEM simulations reveal that even relatively small depths of indent provide sufficiently large reaction forces which are able to balance external loads due to cutting forces and moments.
- The results of experimental investigations confirm that workpiece displacements during machining remain within the boundaries required to provide machining accuracy. More precisely, workpiece displacements are on the 0.01 mm order of magnitude, which keeps the machining error within the desired limits. Experiments also confirmed that the proposed clamping method also provides high surface quality.

Based on the discussion presented in this paper, the authors maintain that the proposed clamping method can find successful application in industry, for the machining of complex geometry workpieces. It allows complete machining to be performed with a single setup and clamping, contributing to reduction of machining error and time.

Further investigation shall be directed towards achieving higher stiffness of the fixture-workpiece system. With this in mind, locating over a single plane, using several auxiliary openings shall be considered. It is supposed that this locating method could provide significantly higher stiffness and lower compliance of the fixture-workpiece system. This is due to the fact that, clamping over three and more auxiliary openings, allows the redistribution of clamping forces which brings into balance cutting forces and moments, while at the same time contributes to reduction of compliance. In addition, it is of special importance to investigate optimal geometry and material selection for fixture elements which are indented into workpiece.

REFERENCES

- [1] Lee, G. B.; Badrul, O. (2014). Optimization for sustainable manufacturing based on axiomatic design principles: a case study of machining processes, *Advances in Production Engineering & Management*, Vol. 9, No. 1, 31-43, doi:[10.14743/apem2014.1.174](https://doi.org/10.14743/apem2014.1.174)
- [2] Bi, Z. M.; Zhang, W. J. (2001). Flexible fixture design and automation: review, issues and future directions, *International Journal of Production Research*, Vol. 39, No. 13, 2867-2894, doi:[10.1080/00207540110054579](https://doi.org/10.1080/00207540110054579)
- [3] Wardak, K. R.; Tasch, U.; Charalambides, P. G. (2001). Optimal fixture design for drilling through deformable plate workpieces part I: model formulation, *Journal of Manufacturing Systems*, Vol. 20, No. 1, 23-32, doi:[10.1016/S0278-6125\(01\)80017-0](https://doi.org/10.1016/S0278-6125(01)80017-0)
- [4] Ostojic, G.; Stankovski, S.; Vukelic, D.; Lazarevic, M.; Hodolic, J.; Tadic, B.; Odri, S. (2011). Implementation of automatic identification technology in a process of fixture assembly/disassembly, *Strojniski vestnik – Journal of Mechanical Engineering*, Vol. 57, No. 11, 819-825, doi:[10.5545/sv-jme.2010.131](https://doi.org/10.5545/sv-jme.2010.131)

- [5] Siebenaler, S. P.; Melkote, S. N. (2006). Prediction of workpiece deformation in a fixture system using the finite element method, *International Journal of Machine Tools and Manufacture*, Vol. 46, No. 1, 51-58, doi:[10.1016/j.ijmachtools.2005.04.007](https://doi.org/10.1016/j.ijmachtools.2005.04.007)
- [6] Prabhakaran, G.; Padmanaban, K. P.; Krishnakumar, R. (2007). Machining fixture layout optimization using FEM and evolutionary techniques, *International Journal of Advanced Manufacturing Technology*, Vol. 32, No. 11-12, 1090-1103, doi:[10.1007/s00170-006-0441-6](https://doi.org/10.1007/s00170-006-0441-6)
- [7] Liu, S.-G.; Zheng, L.; Zhang, Z.-H.; Li, Z.-Z.; Liu, D.-C. (2007). Optimization of the number and positions of fixture locators in the peripheral milling of a low-rigidity workpiece, *International Journal of Advanced Manufacturing Technology*, Vol. 33, No. 7-8, 668-676, doi:[10.1007/s00170-006-0507-5](https://doi.org/10.1007/s00170-006-0507-5)
- [8] Padmanaban, K. P.; Prabhakaran, G. (2008). Dynamic analysis on optimal placement of fixturing elements using evolutionary techniques, *International Journal of Production Research*, Vol. 46, No. 15, 4177-4214, doi:[10.1080/00207540601147297](https://doi.org/10.1080/00207540601147297)
- [9] Padmanaban, K. P.; Arulshri, K. P.; Prabhakaran, G. (2009). Machining fixture layout design using ant colony algorithm based continuous optimization method, *International Journal of Advanced Manufacturing Technology*, Vol. 45, No. 9-10, 922-934, doi:[10.1007/s00170-009-2035-6](https://doi.org/10.1007/s00170-009-2035-6)
- [10] Hunter Alarcon, R.; Rios Chueco, J.; Perez Garcia, J. M.; Vizan Idoipe, A. (2010). Fixture knowledge model development and implementation based on a functional design approach, *Robotics and Computer-Integrated Manufacturing*, Vol. 26, No. 1, 56-66, doi:[10.1016/j.rcim.2009.02.001](https://doi.org/10.1016/j.rcim.2009.02.001)
- [11] Zheng, Y.; Chew, C.-M. (2010). A geometric approach to automated fixture layout design, *Computer-Aided Design*, Vol. 42, No. 3, 202-212, doi:[10.1016/j.cad.2009.10.002](https://doi.org/10.1016/j.cad.2009.10.002)
- [12] Hazarika, M.; Dixit, U. S.; Deb, S. (2010). A setup planning methodology for prismatic parts considering fixturing aspects, *International Journal of Advanced Manufacturing Technology*, Vol. 51, No. 9-12, 1099-1109, doi:[10.1007/s00170-010-2667-6](https://doi.org/10.1007/s00170-010-2667-6)
- [13] Asante, J. N. (2010). Effect of fixture compliance and cutting conditions on workpiece stability, *International Journal of Advanced Manufacturing Technology*, Vol. 48, No. 1-4, 33-43, doi:[10.1007/s00170-009-2284-4](https://doi.org/10.1007/s00170-009-2284-4)
- [14] Lu, J.; Zhang, F.; Zuo, J.; Qian, H.; Ma, N. (2011). Quantitative optimization of workpiece–fixture system's clamping forces, *International Journal of Computational Intelligence Systems*, Vol. 4, No. 3, 402-409, doi:[10.1080/18756891.2011.9727799](https://doi.org/10.1080/18756891.2011.9727799)
- [15] Chaari, R.; Abdennadher, M.; Louati, J.; Haddar, M. (2011). Modelling of the 3D machining geometric defects accounting for workpiece vibratory behaviour, *International Journal of Simulation Modelling*, Vol. 10, No. 2, 66-77, doi:[10.2507/IJSIMM10\(2\)2.173](https://doi.org/10.2507/IJSIMM10(2)2.173)
- [16] Vishnupriyan, S.; Majumder, M. C.; Ramachandran, K. P. (2011). Optimal fixture parameters considering locating errors, *International Journal of Production Research*, Vol. 49, No. 21, 6343-6361, doi:[10.1080/00207543.2010.532167](https://doi.org/10.1080/00207543.2010.532167)
- [17] Vishnupriyan, S. (2012). Effect of system compliance and workpiece dynamics on machining error, *Assembly Automation*, Vol. 32, No. 2, 175-184, doi:[10.1108/01445151211212325](https://doi.org/10.1108/01445151211212325)
- [18] Sun, X.; Chu, X.; Xue, D.; Su, Y.; Tang, C. (2012). An integrated setup/fixture planning approach for machining prismatic parts, *International Journal of Production Research*, Vol. 50, No. 4, 1009-1027, doi:[10.1080/00207543.2010.543172](https://doi.org/10.1080/00207543.2010.543172)
- [19] Vishnupriyan, S.; Muruganandam, A.; Govindarajan, L. (2012). Prediction of workpiece dynamic motion using an optimized artificial neural network, *Proceedings of the Institution of Mechanical Engineers, Part B – Journal of Engineering Manufacture*, Vol. 226, No. 10, 1705-1716, doi:[10.1177/0954405412457121](https://doi.org/10.1177/0954405412457121)
- [20] Siva Kumar, K.; Paulraj, G. (2012). Geometric error control of workpiece during drilling through optimisation of fixture parameter using a genetic algorithm, *International Journal of Production Research*, Vol. 50, No. 12, 3450-3469, doi:[10.1080/00207543.2011.588616](https://doi.org/10.1080/00207543.2011.588616)
- [21] Tadic, B.; Jeremic, B.; Todorovic, P.; Vukelic, D.; Proso, U.; Mandic, V.; Budak, I. (2012). Efficient workpiece clamping by indenting cone-shaped elements, *International Journal of Precision Engineering and Manufacturing*, Vol. 13, No. 10, 1725-1735, doi:[10.1007/s12541-012-0227-8](https://doi.org/10.1007/s12541-012-0227-8)

- [22] Dou, J.; Wang, X.; Wang, L. (2012). Machining fixture layout optimisation under dynamic conditions based on evolutionary techniques, *International Journal of Production Research*, Vol. 50, No. 15, 4294-4315, doi:[10.1080/00207543.2011.618470](https://doi.org/10.1080/00207543.2011.618470)
- [23] Vukelic, D.; Tadic, B.; Miljanic, D.; Budak, I.; Todorovic, P. M.; Randjelovic, S.; Jeremic, B. M. (2012). Novel workpiece clamping method for increased machining performance, *Tehnicki vjesnik – Technical Gazette*, Vol. 19, No. 4, 837-846
- [24] Tadic, B.; Bogdanovic, B.; Jeremic, B. M.; Todorovic, P. M.; Luzanin, O.; Budak, I.; Vukelic, D. (2013). Locating and clamping of complex geometry workpieces with skewed holes in multiple-constraint conditions, *Assembly Automation*, Vol. 33, No. 4, 386-400, doi:[10.1108/AA-09-2012-074](https://doi.org/10.1108/AA-09-2012-074)
- [25] Wan, X.-J.; Zhang, Y.; Huang, X.-D. (2013). Investigation of influence of fixture layout on dynamic response of thin-wall multi-framed work-piece in machining, *International Journal of Machine Tools and Manufacture*, Vol. 75, 87-99, doi:[10.1016/j.ijmachtools.2013.09.008](https://doi.org/10.1016/j.ijmachtools.2013.09.008)
- [26] Liu, Z.; Wang, M. Y.; Wang, K.; Mei, X. (2013). Multi-objective optimization design of a fixture layout considering locator displacement and force-deformation, *International Journal of Advanced Manufacturing Technology*, Vol. 67, No. 5-8, 1267-1279, doi:[10.1007/s00170-012-4564-7](https://doi.org/10.1007/s00170-012-4564-7)
- [27] Xiong, L.; Molfino, R.; Zoppi, M. (2013). Fixture layout optimization for flexible aerospace parts based on self-reconfigurable swarm intelligent fixture system, *International Journal of Advanced Manufacturing Technology*, Vol. 66, No. 9-12, 1305-1313, doi:[10.1007/s00170-012-4408-5](https://doi.org/10.1007/s00170-012-4408-5)
- [28] Tadic, B.; Vukelic, D.; Miljanic, D.; Bogdanovic, B.; Macuzic, I.; Budak, I.; Todorovic, P. (2014). Model testing of fixture-workpiece interface compliance in dynamic conditions, *Journal of Manufacturing Systems*, Vol. 33, No. 1, 76-83, doi:[10.1016/j.jmsy.2013.05.004](https://doi.org/10.1016/j.jmsy.2013.05.004)
- [29] Todorovic, P.; Vukelic, D.; Tadic, B.; Veljkovic, D.; Budak, I.; Macuzic, I.; Lalic, B. (2014). Modelling of dynamic compliance of fixture/workpiece interface, *International Journal of Simulation Modelling*, Vol. 13, No. 1, 54-65, doi:[10.2507/IJSIMM13\(1\)5.254](https://doi.org/10.2507/IJSIMM13(1)5.254)
- [30] Nelaturi, S.; Rangarajan, A.; Fritz, C.; Kurtoglu, T. (2014). Automated fixture configuration for rapid manufacturing planning, *Computer-Aided Design*, Vol. 46, 160-169, doi:[10.1016/j.cad.2013.08.028](https://doi.org/10.1016/j.cad.2013.08.028)